

Breakthrough Technology

What makes the CA-S3 so attractive?

Five years have passed since the company was established.

In that short time, Flying Mole's amps have developed a reputation
for their high quality and tube-like sound.

In keeping with this, we are proud to introduce the CD case sized CA-S3 digital pre-main amplifier.
Our advanced digital technology and high quality standards are incorporated in this ultra slim model.

Its brilliant form symbolizes the spirit of music.

This model empowers users that range from near-field to main systems.



*Cosmetic Design :
by GK Industrial Design*

Audiophile Quality in a Digital Package

CA-S3



Unchanged High Sound Quality Even at Low Level of Volume

Newly developed One Pole Pre-Amplifier (world's first) enables the enjoyment of high quality sound under circumstances where one is forced to listen to music at lower levels, i.e. in the late evenings, etc.

Musicality with High Definition

CA-S3 is equipped with a unique power supply that is three to five times stronger than the conventional. This super-strong power supply impacts this model by offering a stable sound picture and an excellent musicality with high definition.

Original Bi-Phase PWM Amplifier realizes Superb High Sound Quality

The audiophile sound quality of the CA-S3 is made possible by Flying Mole's original Bi-Phase PWM technology. Employment of a 1.2MHz carrier frequency enables vast improvement of resolution and linear reproduction of subtle signal levels. In addition, dual (analog & digital) NFB eliminates the influence to sound quality caused by AC power line voltage fluctuation and the high input capacitance of Power FETs.

Simple Construction for Pure Sound

Circuit construction is very simple. The CA-S3 is not equipped with either input selector or speaker selector. This leads to the pure reproduction of the signal.

Newly Developed Original Speaker Terminal

The solid, gold-plated brass speaker terminals are cone shaped. This shape enables maximum contact area with bare wires, thus, minimizing contact resistance.

The Refined Finish of the Chassis

Non-magnetic pure aluminum is used throughout the housing chassis and is up to 10mm thick (front panel). This secures a solid feel to the unit while suppressing the effect of vibration.

Other Measures for High Sound Quality

- Strictly Selected, Premium Parts and Components
- 27-Level Volume Control Unit with High Accuracy

Green Technology

The unit's total electrical efficiency is 80% at maximum output leading to its coolness (turns electricity into power, not heat), low power consumption (energy saving), and allows for its compact body (resource saving). Components used in the CA-S3 correspond strictly to the RoHS directives^(*) further proving that Flying Mole pays full attention to matters of ecology.

(*) RoHS directive : Restriction of Hazardous Substances(RoHS) directive
Use of six(6) kinds of substances(lead, mercury, cadmium, hexavalent chromium, polybrominated biphenyl and polybrominated biphenyl ether) are restricted.

Specifications

Rated Output Power	20Wx2/8Ω, 20-20kHz 30Wx2/4Ω, 20-20kHz
T.H.D.	0.05% (10W/8Ω/1kHz/15W/4Ω/1kHz)
Frequency Characteristics	20Hz-20kHz (+0dB/-0.5dB) / (8Ω, 1W)
S/N Ratio	98dB
Input Sensitivity	150mV
Input Impedance	50kΩ
Power Consumption	15W
Outer Dimensions	131 (W) x54 (H) x142 (D) mm 5-3/16" (W) x2-1/8" (H) x5-9/16" (D)
Max. Outer Dimensions	131 (W) x54 (H) x179 (D) mm 5-3/16" (W) x2-1/8" (H) x7-1/16" (D)
Weight	1.4Kg / 3lbs1oz.

Characteristics of One Pole Pre-Amplifier(Theory)

Super Wide Range of Frequency: DC~100Hz, 16.5dB Super Low Noise: S/N Ratio 127dB(IHF-A)
Super High Speed Response: Throughrate 1,500V/μs (Actually zero by employing DC Drift Dual FET, Dual TR)

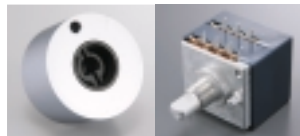
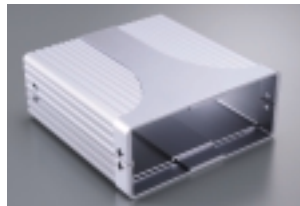
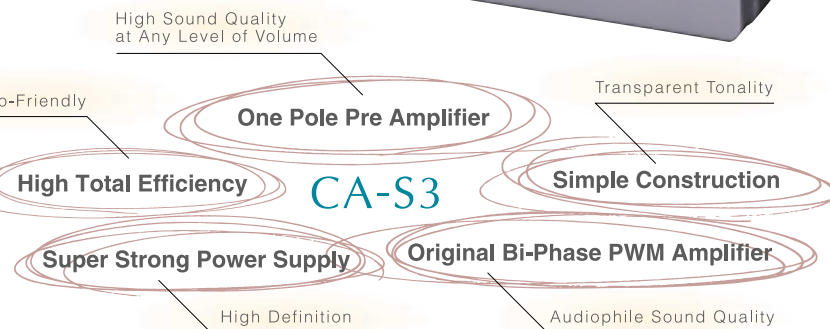

Cosmetic Design : by GK Industrial Design

Block Diagram

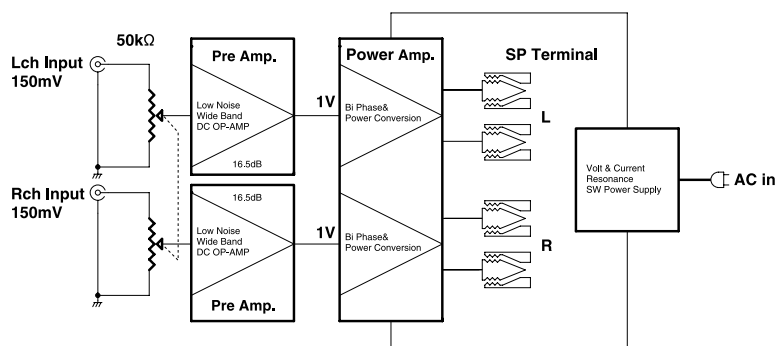

※ Specifications are subject to change without notice.



Flying Mole Corporation

431-1115 Japan, Hamamatsu-shi Waji-cho 5199-1
http://www.flyingmole.co.jp info@flyingmole.co.jp

For detail please contact :